



OPEN ACCESS INTERNATIONAL JOURNAL OF SCIENCE & ENGINEERING

SEISMIC ANALYSIS ON CYLINDRICAL GROUND SUPPORTED WATER TANK BY VARYING THEIR ASPECT RATIO

Chetan Jagtap¹, Siddharth Pastariya²

M.Tech Scholar, Department of Civil Engineering, Sri Aurobindo Institute of Technology Indore M.P¹
Assistant Professor, Department of Civil Engineering, Sri Aurobindo Institute of Technology Indore M.P²

Abstract: Safe drinking water is one of the basic elements for humans to sustain healthy life. Reinforced concrete overhead water tanks are widely used to provide safe drinking water. Most water supply systems in developing countries, such as India, where urbanizing is increasing day by day, rely on overhead storage tanks and hence there is need to construct more number of water tanks. Earlier design of water tanks was done using the working stress method given in IS: 3370 1965. This method leads to thicker and heavily reinforced sections. The use of limit state method of design was then adopted in the revised code IS 3370: 2009 and provision for checking the crack width was included in the code. This study is carried out to analyze the cost of overhead water tanks of a fixed capacity, having different heights and diameters so as to determine the most economical height to diameter (H/D) ratio to be adopted in the design of the tank. To optimize the results and check the accuracy of design, six circular water tanks of 500 kL, with top and bottom dome pattern, were designed by varying H/D ratio from 0.15 to 1.05 in STAAD. Pro. After assuring the safety of all the structures, further analysis is done to calculate the cost-effectiveness of the structures by comparing the approximate total cost of materials. It was found that the aspect ratio (H/D) of 0.60 led to the most efficient design.

Keywords: Water tank, Earthquake, wind load, Hydrostatic load

I INTRODUCTION

In India, prior to the development of seismic codes, many elevated overhead water tanks were designed which suffered severe damages in the events of past earthquakes. Even after the introduction of appropriate seismic codes, these tanks were either designed to be under safe or over safe owing to the lack of in-depth knowledge of seismic design of overhead water tanks (Jabar and Patel 2012). Aspect ratio was found to play a crucial role in determining the overall effectiveness and cost of such tanks. In view of this, this paper explored the design of cylindrical water tanks of fixed capacity (350 kL) with top and bottom dome pattern. They were designed by varying H/D ratio from 0.50 to 0.75 in STAAD. Pro. Six separate models were prepared in STAAD. Pro to check the behaviour of the water tanks under the action of applied gravity and lateral forces, and the total quantity of concrete and steel used for these models was noted to give a preliminary idea about the overall cost of the materials. The thus obtained results were compared to the existing design data for a tank of the same capacity and conclusions were drawn on its feasibility. The first model was given an aspect ratio of $H/D = 0.50$ and the successive models had H/D ratio with an increment of 0.05. An Intze tank was constructed using column and brace-type staging on campus using M25

grade of concrete and Fe415 grade of steel in 2014. The height of the staging was set at 25 m. The tank was designed for zone III seismicity (moderate risk) as per IS:1893 (Part I) (2002) and basic wind pressure of 1.5 kN/ m². The tank was originally designed for a capacity of 2000 students with a demand of 45 L per capita per day. The tank had a design period of 30 years. Soil at site was considered soft clay. To optimize the results and check the accuracy of design, iterative tank design was carried out with different H/D ratio varying from 0.50 to 0.75. Further analysis was then done to calculate the cost-effectiveness of the structures. A circular water tank with a top and bottom dome pattern was adopted as initially proposed at the site.

II METHODOLOGY

The objective of present work is to study of tanks are analyzed for different aspect ratios (h/d) interaction under the seismic loads, Wind Load & Hydro Test. For this, Seven Tanks are considered in different aspect ratio. The performance, behaviour and economy of all seven tanks on the parametric studies of all ground supported tanks are done.

2.1 Description of Structure

Seven type of tanks area taken with different aspect ratio (h/d) for analysis of structure. All seven tanks description are following

- Model I: Height = 2.43 m , Diameter = 16.2m (h/d = 0.15)
- Model II: Height = 3.86 m , Diameter = 12.86 m (h/d = 0.30)
- Model III: Height = 5.06 m , Diameter = 11.23 m (h/d = 0.45)
- Model IV: Height = 6.12 m , Diameter = 10.2 m (h/d = 0.60)
- Model V; Height = 7.11 m , Diameter = 9.46 m (h/d = 0.75)
- Model VI: Height = 8.03 m , Diameter = 8.92 m (h/d = 0.90)
- Model VII: Height = 8.9 m , Diameter = 8.47m (h/d = 1.05)

Thickness of base slabs used is of 250mm and side wall thickness 250 to 450 mm of different aspect ratio of tank. All the structural models were analyzed using Equivalent Static Method. The analyses of structures for all zones i.e. zone II TO zone V under seismic loadings are done by using structural analysis software STAAD PRO.

2.2 Load consideration

1. Dead load- Dead Load in a building should be comprised of weight of all walls, partition, floors, roofs and should include the weight of all other permanent construction in that building. Dead Load for design purpose is assessed as per IS 875:1987 (part I). In this study, dead load is taken as self weight by software itself.
2. Earthquake load- Earthquake design is done in accordance with IS 1893 (part I):2002 and has been taken by specifying the zone in which structure is located. These tanks are located in zone II zone V. The parameter to be used for analysis and design are given below:-

Table 2.1- Earthquake Parameters

Zone factor (Z)	II to V	0.16 and 0.36
Response Reduction factor (RF)	SMRF	2.5
Importance factor	All general building	1
Rock/Soil type	Hard, Soft & Medium soil	1 to 3
Damping Ratio		5%
Fundamental natural period of vibration (Ta)		0.09*h/(d)0.5

3. Wind load- Wind load is done in accordance with IS 873 (part III):2015 and has been taken by specifying the basic wind speed. These tanks design in wind load the various factors & parameter are depends. The parameter to be used for analysis and design are given below:-

Table 2.2- Wind Load Parameters

Basic Wind Speed	Vb	39 m/s
Risk coefficient	k1	1
Terrain height, structure size factor	k2	1
Topography factor	k3	1
Design wind speed	Vz	Vbxk1xk2xk3
Design wind pressure	Pd	0.6 x Vz2

III MODELLING APPROACH:

Equivalent Static Method is used to analyze various models by using staad pro software. Different models are prepared for different cases to analyze water tanks of various aspect ratio. The various conditions of water tanks are used to study the effect of changing water full, half fill and empty condition. Introduction of water tanks in the structural system provides stability against loads i.e. wind, seismic, hydrostatic and soil pressure. The performance, behavior and economy of all seven tanks on the parametric studies of all ground supported tanks are done. The modeling approach includes types of cases considered for analysis of structure, the development and analysis of models and details of models. Then linear static analysis has been carried out for all zones and no zone for structural analysis.

3.1 Types of cases used for analysis of structure

There are different cases considered for varying conditions of tank full, tank half fill and tank empty. Varying thickness and different aspect ratio to analyze structure, so that proper results can be analyzed.

Case A– Water Tank with full water (Hydro Test + seismic)

- Model I - Aspect ratio (h/d=0.15).
- Model II – Aspect ratio (h/d=0.30).
- Model III – Aspect ratio (h/d=0.45).
- Model IV -Aspect ratio (h/d=0.60).
- Model V - Aspect ratio (h/d=0.75).
- Model VI – Aspect ratio (h/d=0.90).
- Model VII – Aspect ratio (h/d=0.105).

To study the behavior, the response parameters selected are lateral displacement, column shear, storey drift, drift reduction factor, contribution factor. All the cases are assumed to be located in Zone IV and Zone V.

3.2 Development of Models

Model I: Height = 2.43 m , Diameter = 16.2m (h/d = 0.15)

Model II: Height = 3.86 m , Diameter = 12.86 m (h/d = 0.30)

Model III: Height = 5.06 m , Diameter = 11.23 m (h/d = 0.45)

Model IV: Height = 6.12 m , Diameter = 10.2 m (h/d = 0.60)

Model V: Height = 7.11 m , Diameter = 9.46 m (h/d = 0.75)

Model VI: Height = 8.03 m , Diameter = 8.92 m (h/d = 0.90)

Model VII: Height = 8.9 m , Diameter = 8.47m (h/d = 1.05)

Table 3.1- Dimensions of all Seven Tanks:-

S no	Model Description	Height (m)	Diameter (m)	H/D
1	TANK 1	2.43	16.2	0.15
2	TANK 2	3.86	12.86	0.30
3	TANK 3	5.06	11.23	0.45
4	TANK 4	6.12	10.2	0.60
5	TANK 5	7.11	9.47	0.75
6	TANK 6	8.03	8.92	0.90
7	TANK 7	8.9	8.47	1.05

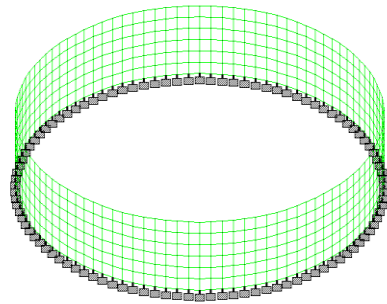

Model I

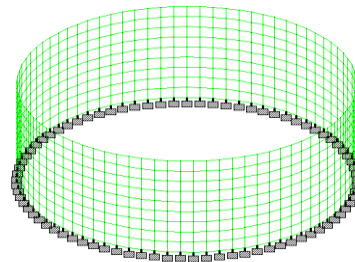

Model II

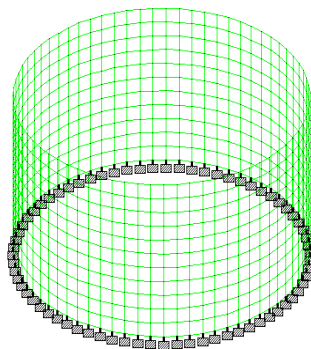

Model III

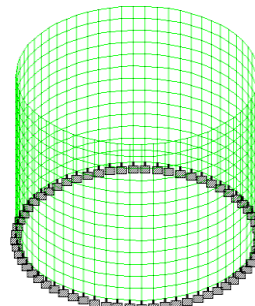

Model IV

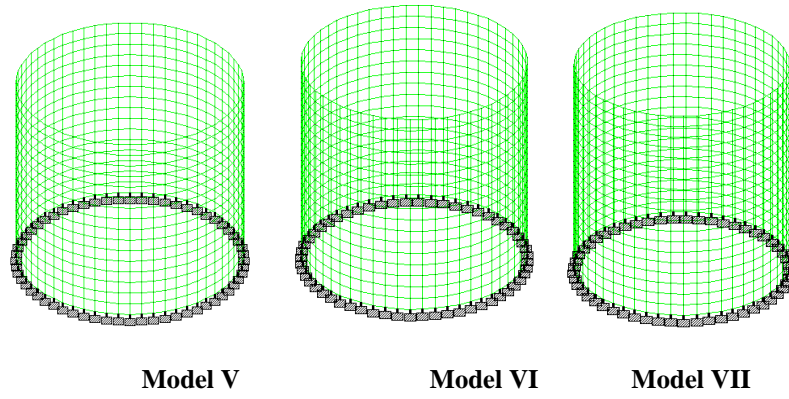

Figure 3.1- Models of all Seven Tanks

LOADS ON TANK

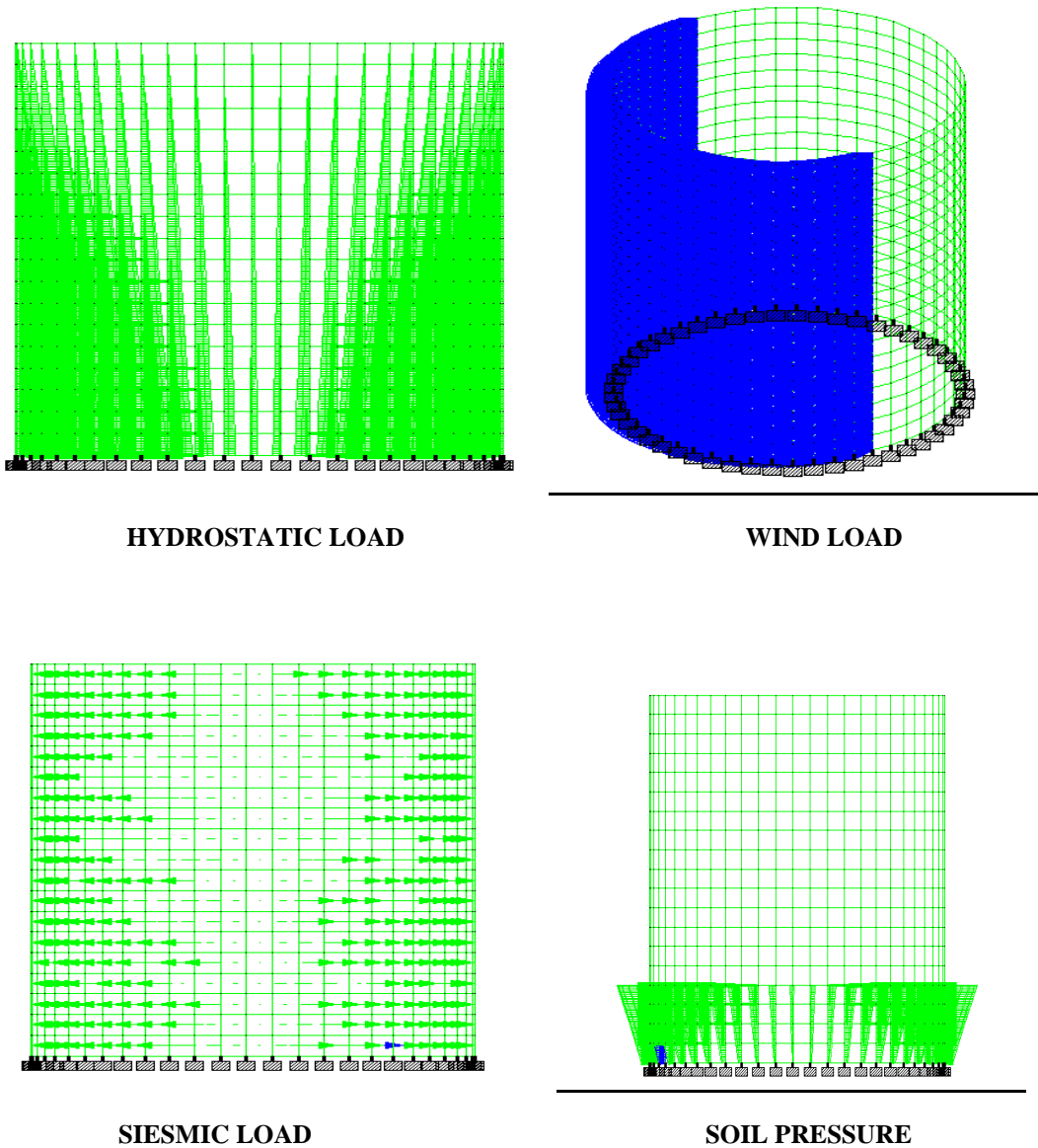

Figure 3.2 – Loads Behavior on Tanks

IV RESULT & DISCUSSION

4.1 - Case B – Water Tank with half full water (Soil Pressure + Wind Pressure + Surchage).

Table 4.1- Moment in X & Y Direction & Shear Force in X direction

Tank	Aspect Ratio	Mx(kNm/m)	My(kNm/m)	Sx(N/mm2)
1	0.15	0.68	7.51	0.124
2	0.3	0.837	9.3	0.322
3	0.45	1.25	11.654	0.674
4	0.6	2.615	15.55	0.97
5	0.75	3.009	17.7	1.022
6	0.9	3.215	18.8	1.201
7	1.05	3.95	20.498	1.344

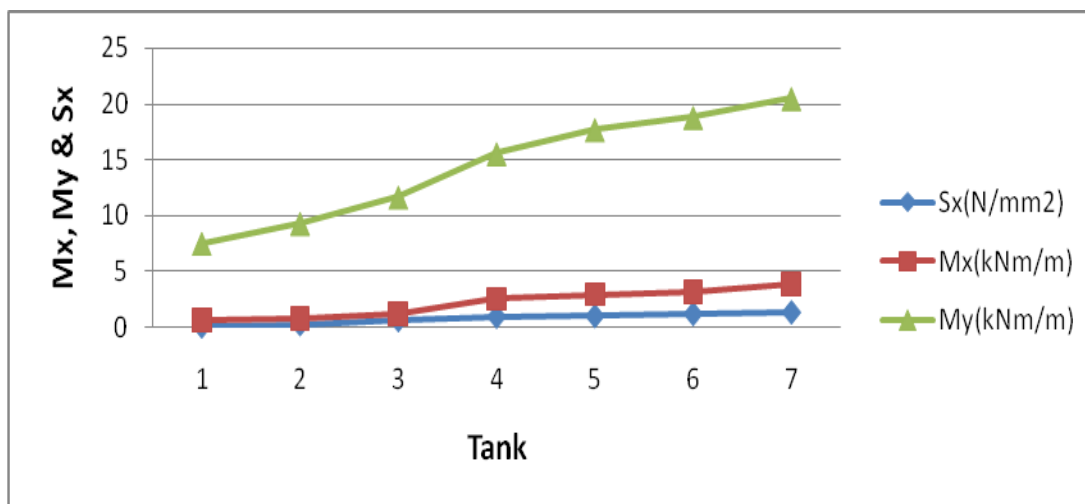

Graph 1 Moments & Shear forces behavior in soil pressure + wind pressure + surcharge.

4.2 - Case C- Water Tank with Empty water (Wind Pressure + Surchage).

Table 4.2 Moment in X & Y Direction & Shear Force in X direction

Tank	Aspect Ratio	Mx(kNm/m)	My(kNm/m)	Sx(N/mm2)
1	0.15	0.587	3.45	0.087
2	0.3	0.704	4.142	0.174
3	0.45	0.615	3.619	0.478
4	0.6	0.25	1.47	0.654
5	0.75	0.309	1.86	0.987
6	0.9	0.709	4.203	1.011
7	1.05	0.67	3.991	1.199

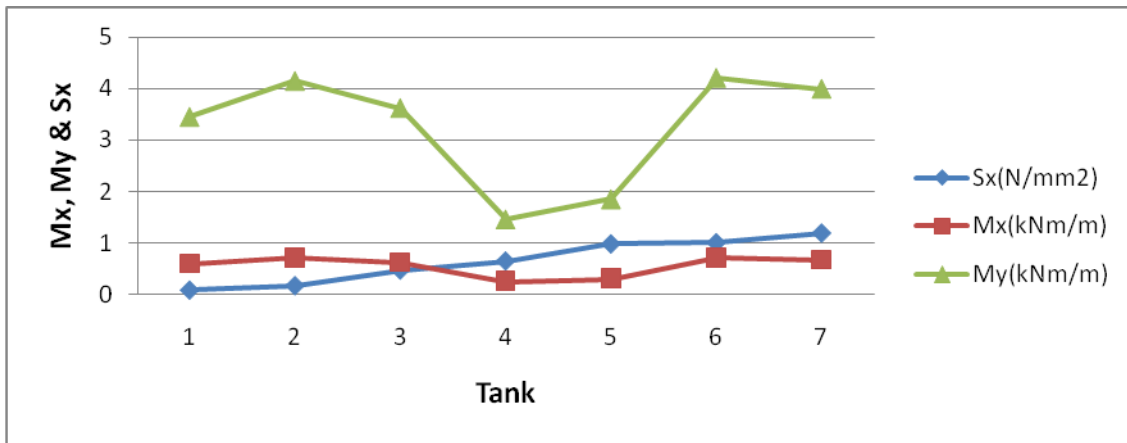

Graph 2 Moments & Shear forces behaviour in Wind Pressure + surcharge.

Table 4.3- Quantity of Steel:-

Tank	Aspect Ratio	Total Steel in Kg
1	0.15	9758.18
2	0.3	9018.42
3	0.45	8573.58
4	0.6	9575.08
5	0.75	9893.52
6	0.9	11346.96
7	1.05	12725.52

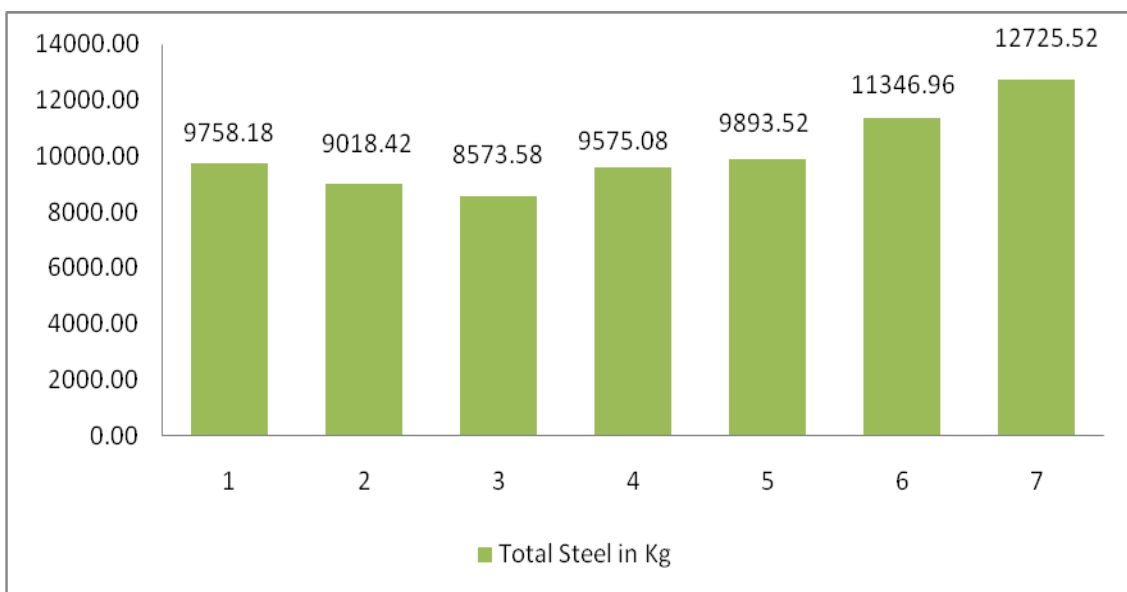

Graph 3 - Quantity of Steel in all Seven Tanks

Table 4.4- Cost of Steel:-

Tank	Aspect Ratio	Total Steel in Kg	Rate	Amount
1	0.15	9758.18	60	585490.80
2	0.3	9018.42	60	541105.20
3	0.45	8573.58	60	514414.80
4	0.6	9575.08	60	574504.80
5	0.75	9893.52	60	593611.20
6	0.9	11346.96	60	680817.60
7	1.05	12725.52	60	763531.20

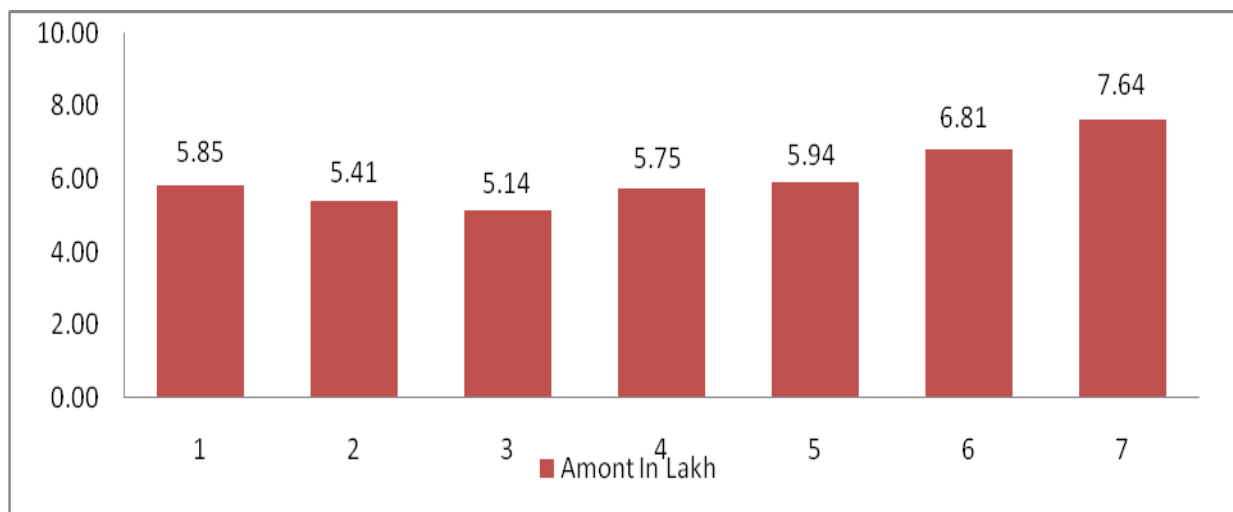

Graph 4- Cost of Steel in all Seven Tanks.

Table 4.5- Cost Abstract:-

Tank	Aspect Ratio	Amount of Concrete	Amount of Steel	Total Amount	Total Amount In Lakh
1	0.15	547700.00	585490.80	1133190.80	11.33
2	0.3	516900.00	541105.20	1058005.20	10.58
3	0.45	510000.00	514414.80	1024414.80	10.24
4	0.6	517200.00	574504.80	1091704.80	10.92
5	0.75	571600.00	593611.20	1165211.20	11.65
6	0.9	636350.00	680817.60	1317167.60	13.17
7	1.05	707550.00	763531.20	1471081.20	14.71

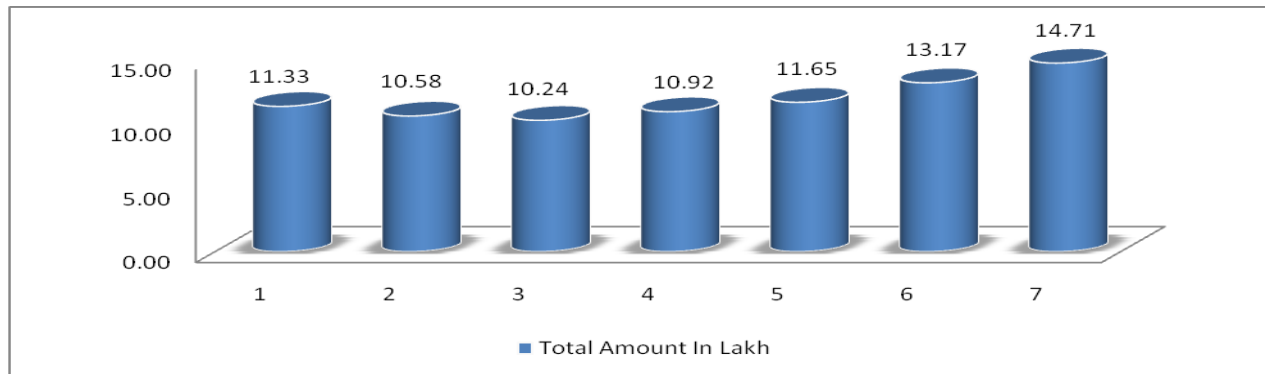

Graph 5–Total Amount of all Seven Tanks.

V CONCLUSION

This study was carried out to analyze the cost of overhead water tanks of a fixed capacity, having different heights and diameters so as to determine the most economical height to diameter (H/D) ratio to be adopted in the design of the tank. To optimize the results and check the accuracy of design, six circular water tanks of 500 kL, with top and bottom dome pattern, were designed by varying the H/D ratio from 0.15 to 1.05 in STAAD.Pro. It is clear to all that the loading hazards have to be carefully evaluated before the construction of important and high-rise structures such as overhead water tanks. Based on the above analytical study carried out on six different models with different diameters and heights, the following conclusions are drawn:

1. For the same capacity of tank, there exist numerous possibilities of height and diameter combinations for the tank.
2. In all the cases, the diameter was linearly decreased by an amount of 0.2 m starting from 10 m. It was seen that tanks with larger diameters had smaller heights and thus covered a larger ground span.
3. The tanks with smaller diameters generally require lesser volume of concrete. However, a linear relationship does not exist between the readings.
4. The volume of steel was observed to be higher in cases of tanks having smaller diameter.
5. In higher seismically active zone, the earthquake hazard will also increase. In such cases, further analysis will be required to accurately estimate the behaviour of the structure.

REFERENCES

[1] Anup Y Naik¹, Rakshan K M², Ashok P G³ (2015): Seismic Analysis of Completely Buried Rectangular Concrete Reservoir, International Research Journal of Engineering and Technology (IRJET), PP:709-714.

[2] P. MUTHU VIJAY¹ & AMAR PRAKASH² (2014): ANALYSIS OF SLOSHING IMPACT ON OVERHEAD LIQUID STORAGE STRUCTURES International Journal of Research in Engineering & Technology PP: 127-142.

[3] Uma Chaduvulaa, Deepam Patela, N Gopala krishnanb (2013):: Fluid-Structure-Soil Interaction Effects on Seismic Behaviour of Elevated Water Tanks, PP:84-91.

[4] S. Nicolici * , R.M. Bilegan (2013): Fluid structure interaction modeling of liquid sloshing phenomena in flexible tanks, Nuclear Engineering and Design ,PP:51-56.

[5] SYED SAIF UDDIN (2013): SEISMIC ANALYSIS OF LIQUID STORAGE TANKS, International Journal of Advanced Trends in Computer Science and Engineering, Pages : 357 – 362

[6] M. Moslemi, M.R. Kianoush (2012): Parametric study on dynamic behavior of cylindrical ground-supported tanks, Engineering Structures, PP:214-230

[7] MostafaMasoudia,b,† , SassanEshghi b, Mohsen Ghafory-Ashtiany b(2012): Evaluation of response modification factor (R) of elevated concrete tanks, Engineering Structures journal homepage: www.elsevier.com/locate/engstruct, PP:199-209.

[8] H. Kazema, S. Mehrpouya*^b (2012): Estimation of Sloshing Wave Height in Broad Cylindrical Oil Storage Tanks Using Numerical Methods, Journal of Structural Engineering and Geotechnics, PP:55-59

[9] M.R. Kianoush * , A.R. Ghaemmaghami (2011): The effect of earthquake frequency content on the seismic behavior of concrete rectangular liquid tanks using the finite element method incorporating soil–structure interaction, Engineering Structures journal homepage: www.elsevier.com/locate/engstruct, PP:2186-2200

[10] HasanJasim Mohammed (2011): Economical Design of Water Concrete Tanks, European Journal of Scientific Research, pp. 510-520.

[11] A. R. Ghaemmaghami¹ and M. R. Kianoush² (2010): Effect of Wall Flexibility on Dynamic Response of Concrete Rectangular Liquid Storage Tanks under Horizontal and Vertical Ground Motions.

[12] Halil Sezena, Ramazan Livaoglub, Adem Dogangunc (2008): Dynamic analysis and seismic performance evaluation of above-ground liquid-containing tanks, Engineering Structures 30 (2008) 794–803.

[13] O R Jaiswal¹, Shraddha Kulkarni² and Pavan Pathak² (2008): A STUDY ON SLOSHING FREQUENCIES OF FLUID-TANK SYSTEM, The 14th World Conference on Earthquake Engineering October 12-17, 2008, Beijing, China.